

extenza
by  **ecopoint**

Established in 2008, Ecopoint is 100% New Zealand owned and operated, specialising in the manufacture and supply of specification-grade LED lighting solutions at competitive prices.

Ecopoint designs and produces LED lighting products under license in China, as well as sourcing high quality products from specialist manufacturers. Based out of Wellington, New Zealand, with offices in Auckland, Christchurch and China.

We focus on commercial and industrial lighting requirements, where via a process of collaboration with clients we ensure that they receive the best possible lighting solutions via a combination of local technical and design expertise and quality control based on site in China.

Due to these elements Ecopoint is confident that our industry leading combination of affordability and quality ensures that clients achieve their energy efficiency, maintenance and luminance goals, be it for their retrofit or new build requirements.

Ecopoint is pleased to announce the introduction of our Architectural range, Extenza. Bringing the core Ecopoint values of Quality, Performance and Value for Money to the design arena with the introduction of OptaSoft, OptaLine, OptaOmni and OptaVert.

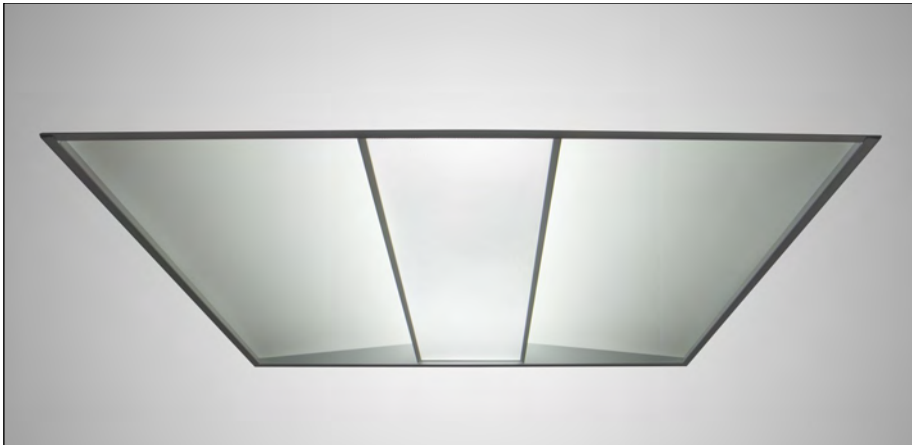

Description:

Combining good efficacy with a comfortable soft-glow appearance, the OptaSoft is an appealing option for office spaces aiming for a different look. Three standard sizes — 600 x 600, 300 x 1200 and 600 x 1200 — mean that there is a solution that fits most ceiling configurations in both retrofit or new fit-out situations. A micro-prism central diffuser as the primary optic is balanced by a secondary glow from the frosted side 'wings', helping to ease glare and improve visual comfort.

Mounting:

Recessed (T-rail ceilings). Supplied with a pair of restraint cables. Enquire for plaster recess and surface-mounting options.

Key Applications:

Offices, Meeting rooms, Foyers, Commercial fit-outs, Retail etc.

GENERAL SPECIFICATIONS:

Electrical Supply	220-240 V AC / 50-60 Hz
Driver Specifications	> 0.9 PF (>0.95 typ.), THD<10% (Std.) / THD<7% (DALI)
Dimming Options	DALI, CASAMBI
Colour Specifications	4000K (3000K, 5000K opt.) / R _a > 80 / 3 SDCM
Operating Temperatures	- 20 to 40 deg. C
Construction	Sheet metal body, PMMA diffuser
Colour Options	White

STANDARD MODELS

Type	Size (mm)	Mass (kg)	Optic	Power	Flux*	Lumen Maintenance**
OptaSoft 6X6	595 x 595 x 100	6.8	Microprismatic (UGR<19)	32 W	3,560 lm	L90 @ 45,000 hrs (B10) L80 @ 94,000 hrs (B10)
OptaSoft 3X12	295 x 1195 x 100	7.0	Microprismatic (UGR<19)	32 W	3,440 lm	L90 @ 45,000 hrs (B10) L80 @ 94,000 hrs (B10)
OptaSoft 6X12	595 x 1195 x 100	11.0	Microprismatic (UGR<19)	40 W	4,800 lm	L90 @ 44,000 hrs (B10) L80 @ 92,000 hrs (B10)

Notes:

* Flux values relate to CRI>80, 4000K versions.

** Lumen maintenance per TM-21 at t_a 35° C (9,000 hrs LM-80 data; predictions beyond 54,000 hrs are outside of TM-21 reporting guidelines and indicative only).

POLAR DIAGRAM

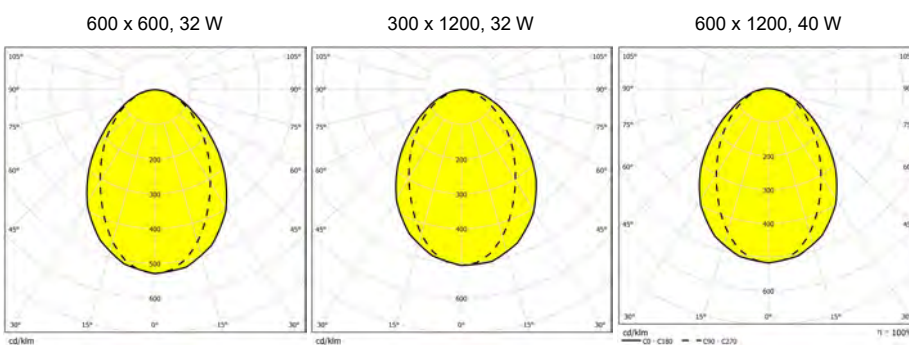

DIMENSIONS

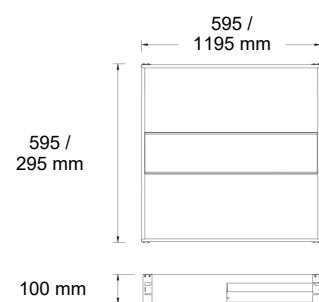

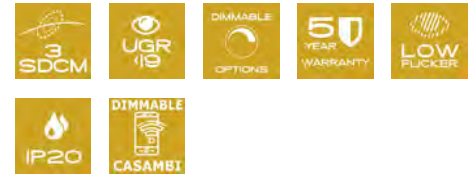

Description:

The OptaLine profile luminaire family combines a user-friendly modular design with sleek and minimal lines which will suit a wide variety of architectural and commercial applications. Using three module lengths, a simple seamless joining system and through-wiring, continuous runs can be achieved with a single power feed. Use these luminaires over workstations with the 60° optic to provide targeted task illumination or choose the tight 15° optic for spotlighting and wall-grazing. Choose either the black or white option to suit your interior colour scheme.

Mounting:

Suspended or surface-mounted; individual or continuous (up to 20 m, through-wired)

Key Applications:

Offices, Meeting rooms, Foyers, Receptions, Retail spaces, Accent/task lighting etc.

GENERAL SPECIFICATIONS:

Electrical Supply	200-240 V AC / 47-63 Hz
Driver Specifications	> 0.9 PF (>0.95 typ.), THD<10%
Dimming Options	Non-dim, DALI, CASAMBI
Colour Specifications	4000K (3000K opt.) / $R_a > 80$ / 3 SDCM
Operating Temperatures	- 10 to 40 deg. C
Construction	Extruded aluminium, PC lens
Colour Options	White, Black

STANDARD MODELS

Type	Size (mm)	Mass (kg)	Optic	Power	Flux*	Lumen Maintenance**
OptaLine 300	305 x 60 x 88	0.9	Lens (15°/36°/60°), UGR<19	10 W	700 lm	L90 @ 25,000 hrs (B10)
OptaLine 600	605 x 60 x 88	1.7	Lens (15°/36°/60°), UGR<19	20 W	1,550 lm	L90 @ 25,000 hrs (B10)
OptaLine 1200	1205 x 60 x 88	3.1	Lens (15°/36°/60°), UGR<19	38 W	3,200 lm	L90 @ 25,000 hrs (B10)

Notes:

* Flux values relate to CRI>80, 4000K versions with 60° lens optic.

** Lumen maintenance per TM-21 at t_a 25° C (6,000 hrs LM-80 data; predictions beyond 36,000 hrs are outside of TM-21 reporting guidelines and indicative only).

POLAR DIAGRAM

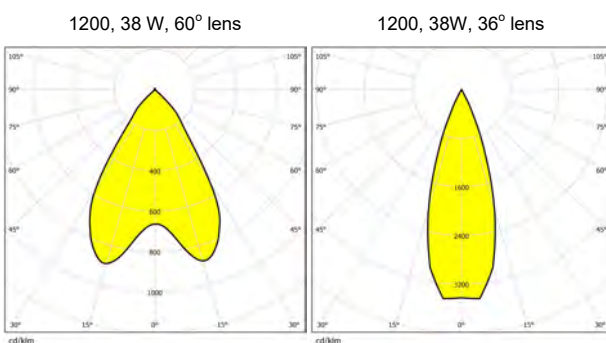

DIMENSIONS

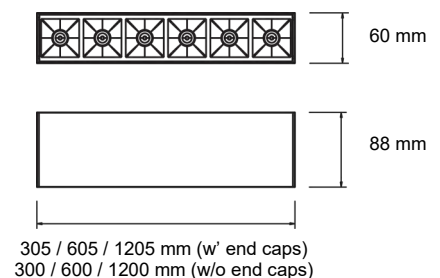



Description:

The OptaOmni is a low-profile luminaire in a few ways — its shallow dimensions give it a sleek appearance from across the room, while the semi-transparent diffuser reduces its presence when viewed from below. This doesn't compromise its performance though; direct and indirect light is provided efficiently and with well-controlled glare. The ability to mount these in continuous runs only enhances its flexibility, with arrangements of up to 12 meters possible from a single power feed.

Mounting:

Suspended; individual or continuous (up to 10 luminaires, through-wired)

Key Applications:

Offices, Meeting rooms, Foyers, Commercial fit-outs, Receptions, Retail etc.

GENERAL SPECIFICATIONS:

Electrical Supply	220-240 V AC / 50-60 Hz
Driver Specifications	> 0.9 PF, THD<20%
Dimming Options	Non-dim, 1-10V, CASAMBI, DALI (requires external driver)
Colour Specifications	4000K (3000K, 5000K opt.) / $R_a > 80$ / 3 SDCM
Operating Temperatures	- 20 to 45 deg. C
Construction	Extruded aluminium frame, PMMA diffuser
Colour Options	White, Black

STANDARD MODELS

Type	Size (mm)	Mass (kg)	Optic	Power	Flux*	Lumen Maintenance**
OptaOmni	200 x 1200 x 24	4.7	Direct/Indirect (UGR<19)	40 W	4,600 lm	L90 @ 44,000 hrs (B10) L80 @ 91,000 hrs (B10)
OptaOmni Wide	300 x 1200 x 24	5.0	Direct/Indirect (UGR<19)	54 W	5,300 lm	L90 @ 4 4,000 hrs (B10) L80 @ 91,000 hrs (B10)

Notes:

* Flux values relate to CRI>80, 4000K versions.

** Lumen maintenance per TM-21 at t_a 35° C (9,000 hrs LM-80 data; predictions beyond 54,000 hrs are outside of TM-21 reporting guidelines and indicative only).

POLAR DIAGRAM

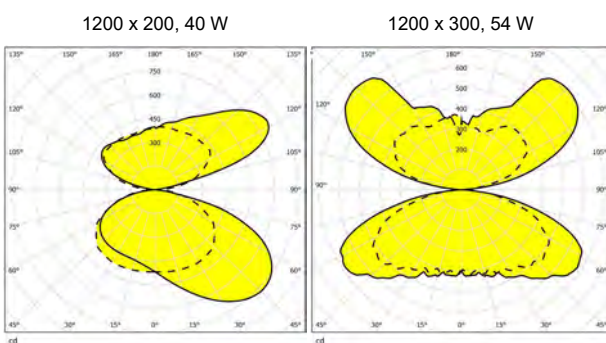

DIMENSIONS

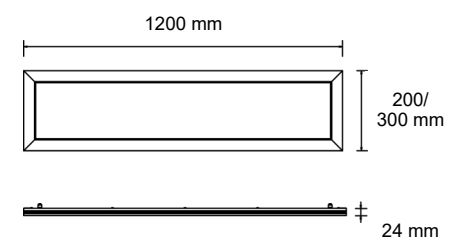



Description:

OptaTube 60 is simple and versatile, with performance to match its compact dimensions. A variety of mounting options means that you can deliver a range of lighting effects and implementations while maintaining a common aesthetic. High colour performance is standard, with an option for even higher specifications for colour-critical applications. Choose either the black or white option to suit your interior colour scheme.

Mounting:

Track-mount spotlight, suspended downlight, surface-mounted spotlight or surface-mounted downlight.

Key Applications:

Offices, Meeting rooms, Foyers, Receptions, Retail spaces, Accent/task lighting etc.

GENERAL SPECIFICATIONS:

Electrical Supply	200-240 V AC / 50-60 Hz
Driver Specifications	> 0.9 PF, THD<15%
Dimming Options	Non-dim, DALI
Colour Specifications	3000K, 4000K / R _a > 90, > 95 / 3 SDCM
Operating Temperatures	- 20 to 40 deg. C
Construction	Powder-coated aluminium, PC lens
Colour Options	White, Black

STANDARD MODELS

Type	Size (mm)	Mass (kg)	Optic	Power	Flux*	Lumen Maintenance**
OptaTube 60 Track	Ø62 x 180	0.64	Lens (16°/24°/36°); interchangeable	15 W	1,530 lm	L90 @ 30,000 hrs (B10) L80 @ 76,000 hrs (B10)
OptaTube 60 Spot	Ø62 x 180	0.50		15 W	1,530 lm	
OptaTube 60 Downlight	Ø62 x 174	0.45		15 W	1,530 lm	
OptaTube 60 Pendant (1.0 m suspension)	Ø62 x 184	0.45		15 W	1,530 lm	

Notes:

* Flux values relate to CRI>90, 4000K versions with 36° lens optic.

** Lumen maintenance per TM-21 at t_a 30° C (15,000 hrs LM-80 data).

POLAR DIAGRAM

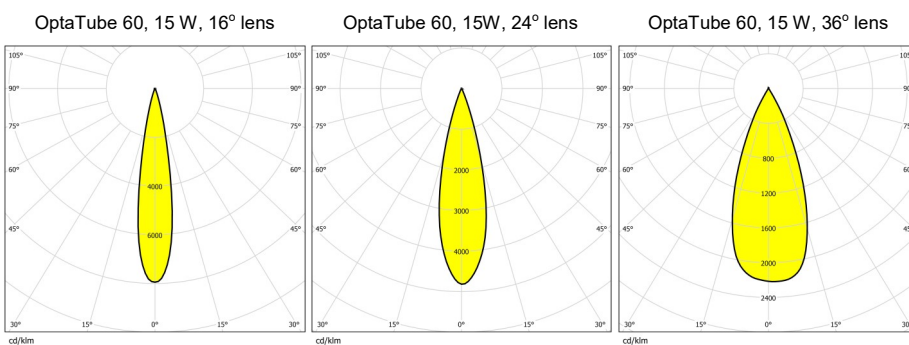

DIMENSIONS

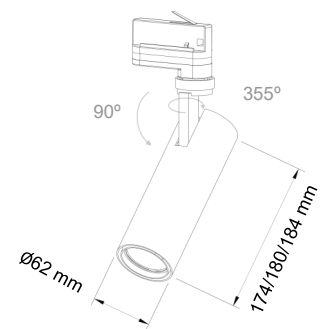



Description:

OptaTube 80 is simple and versatile, with performance to match its compact dimensions. A variety of mounting options means that you can deliver a range of lighting effects and implementations while maintaining a common aesthetic. High colour performance is standard, with an option for even higher specifications for colour-critical applications. Choose either the black or white option to suit your interior colour scheme.

Mounting:

Track-mount spotlight, suspended downlight, surface-mounted spotlight or surface-mounted downlight.

Key Applications:

Offices, Meeting rooms, Foyers, Receptions, Retail spaces, Accent/task lighting etc.

GENERAL SPECIFICATIONS:

Electrical Supply	200-240 V AC / 50-60 Hz
Driver Specifications	> 0.9 PF, THD<15%
Dimming Options	Non-dim, DALI
Colour Specifications	3000K, 4000K / R _a > 90, > 95 / 3 SDCM
Operating Temperatures	- 20 to 40 deg. C
Construction	Powder-coated aluminium, PC lens
Colour Options	White, Black

STANDARD MODELS

Type	Size (mm)	Mass (kg)	Optic	Power	Flux*	Lumen Maintenance**
OptaTube 80 Track	Ø82 x 174	0.83		20 W	1,970 lm	
OptaTube 80 Spot	Ø82 x 180	0.85	Lens (12°/24°/45°); interchangeable	20 W	1,970 lm	L90 @ 31,000 hrs (B10) L80 @ 76,000 hrs (B10)
OptaTube 80 Downlight	Ø82 x 174	0.65		20 W	1,970 lm	
OptaTube 80 Pendant	Ø82 x 174 (1.0 m suspension)	0.65		20 W	1,970 lm	

Notes:

* Flux values relate to CRI>90, 4000K versions with 45° lens optic.

** Lumen maintenance per TM-21 at t_a 30° C (15,000 hrs LM-80 data).

POLAR DIAGRAM

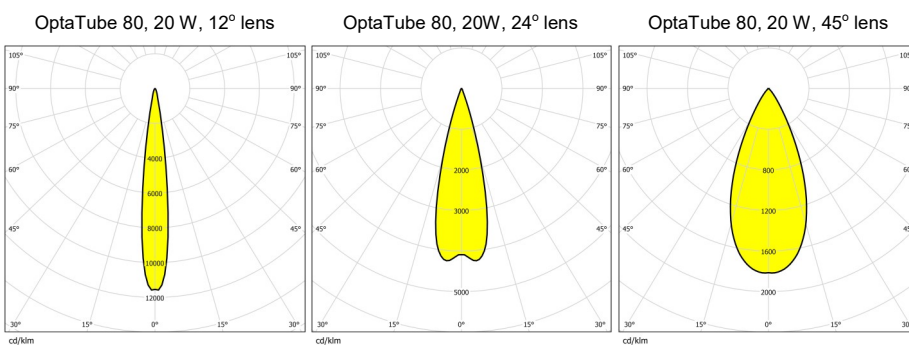

DIMENSIONS

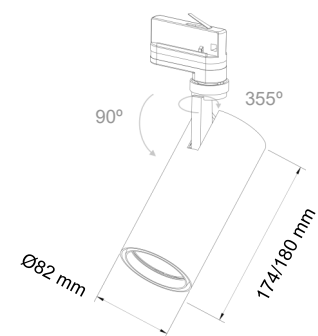



Description:

OptaTube 110 is a powerful package with modest dimensions and a simple form. A variety of mounting options means that you can deliver a range of lighting effects and implementations while maintaining a common aesthetic. High colour performance is standard, with an option for even higher specifications for colour-critical applications. Choose either the black or white option to suit your interior colour scheme.

Mounting:

Track-mount spotlight, suspended downlight, surface-mounted spotlight or surface-mounted downlight.

Key Applications:

Offices, Meeting rooms, Foyers, Receptions, Retail spaces, Accent/task lighting etc.

GENERAL SPECIFICATIONS:

Electrical Supply	200-240 V AC / 50-60 Hz
Driver Specifications	> 0.9 PF, THD<15%
Dimming Options	Non-dim, DALI
Colour Specifications	3000K, 4000K / R _a > 90, > 95 / 3 SDCM
Operating Temperatures	- 20 to 40 deg. C
Construction	Powder-coated aluminium, PC lens
Colour Options	White, Black

STANDARD MODELS

Type	Size (mm)	Mass (kg)	Optic	Power	Flux*	Lumen Maintenance**
OptaTube 110 Track	Ø110 x 158	0.95	Reflector (15°/20°/45°); interchangeable	20 W 30 W	1,880 lm 2,800 lm	L90 @ 30,000 hrs (B10) L80 @ 76,000 hrs (B10)
OptaTube 110 Spot	Ø110 x 158	1.15		20 W 30 W	1,880 lm 2,800 lm	
OptaTube 110 Downlight	Ø110 x 158	1.15		20 W 30 W	1,880 lm 2,800 lm	
OptaTube 110 Pendant (1.0 m suspension)	Ø110 x 158	1.70		20 W 30 W	1,880 lm 2,800 lm	

Notes:

* Flux values relate to CRI>90, 4000K versions with 45° lens optic.

** Lumen maintenance per TM-21 at t₈₀ 30° C (15,000 hrs LM-80 data).

POLAR DIAGRAM

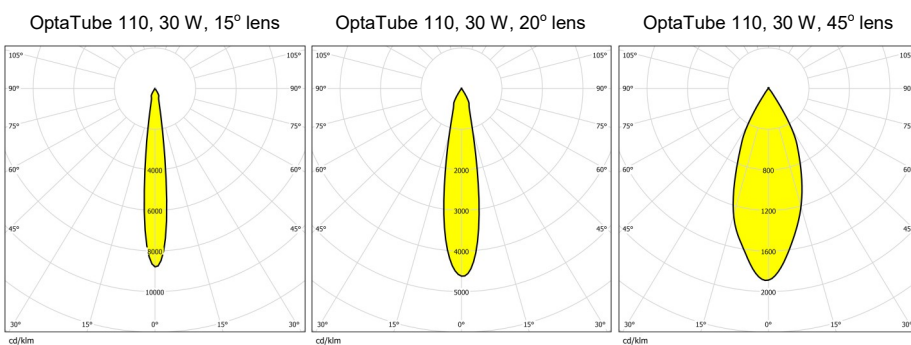

DIMENSIONS

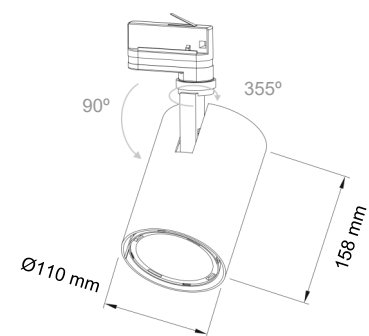



Description:

OptaTube 130 delivers focused accent lighting for applications where high power is required, especially in retail environments. A variety of mounting options means that you can deliver a range of lighting effects and implementations while maintaining a common aesthetic. High colour performance is standard, with an option for even higher specifications for colour-critical applications. Choose either the black or white option to suit your interior colour scheme.

Mounting:

Track-mount spotlight, suspended downlight, surface-mounted spotlight or surface-mounted downlight.

Key Applications:

Offices, Meeting rooms, Foyers, Receptions, Retail spaces, Accent/task lighting etc.

GENERAL SPECIFICATIONS:

Electrical Supply	200-240 V AC / 50-60 Hz
Driver Specifications	> 0.9 PF, THD<15%
Dimming Options	Non-dim, DALI
Colour Specifications	3000K, 4000K / R _a > 90, > 95 / 3 SDCM
Operating Temperatures	- 20 to 40 deg. C
Construction	Powder-coated aluminium, PC lens
Colour Options	White, Black

STANDARD MODELS

Type	Size (mm)	Mass (kg)	Optic	Power	Flux*	Lumen Maintenance**
OptaTube 130 Track	∅126 x 180	1.75	Reflector (12°/20°/45°); interchangeable	40 W 50 W	3,640 lm 3,980 lm	L90 @ 31,000 hrs (B10) L80 @ 76,000 hrs (B10)
OptaTube 130 Spot	∅126 x 182	1.55				
OptaTube 130 Downlight	∅126 x 180	1.80				
OptaTube 130 Pendant (1.0 m suspension)	∅126 x 180	1.80		40 W 50 W	3,640 lm 3,980 lm	

Notes:

* Flux values relate to CRI>90, 4000K versions with 45° lens optic.

** Lumen maintenance per TM-21 at t_a 30° C (15,000 hrs LM-80 data).

POLAR DIAGRAM

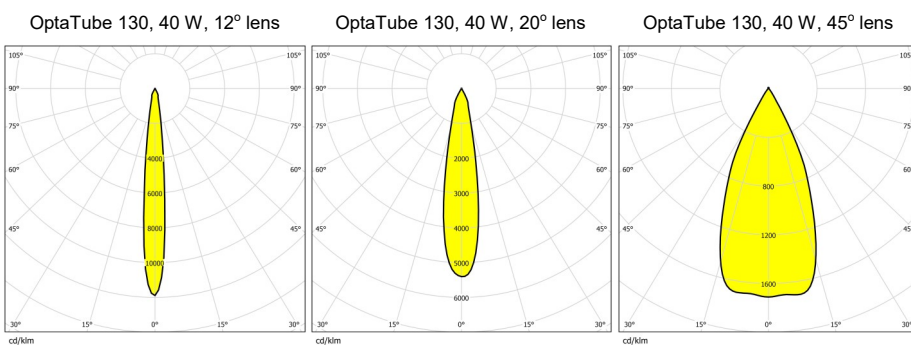

DIMENSIONS

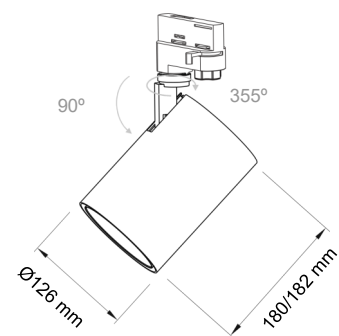

BARN DOORS

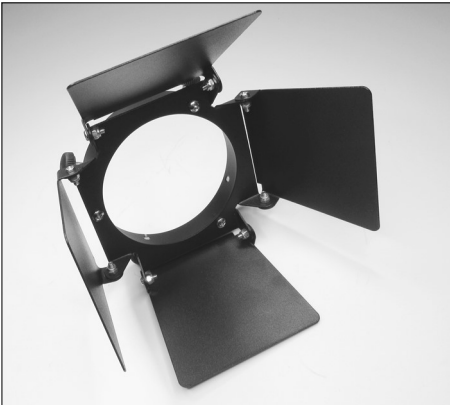

Description:

When a spot-lighting application requires the beam to be manually modified to 'frame' a feature or display, Barn Doors are a means of restricting the distribution on four sides of the beam, independently, to create elongated 'rectangular' or 'square' beams or even just to prevent light spill in specific directions.

Barn Doors are available to suit all four OptaTube sizes — OptaTubes 60, 80, 110, and 130.



HONEYCOMB FILTER

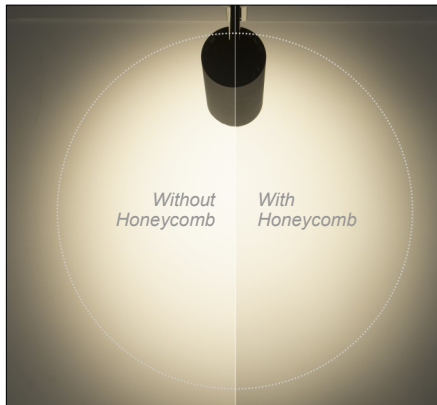
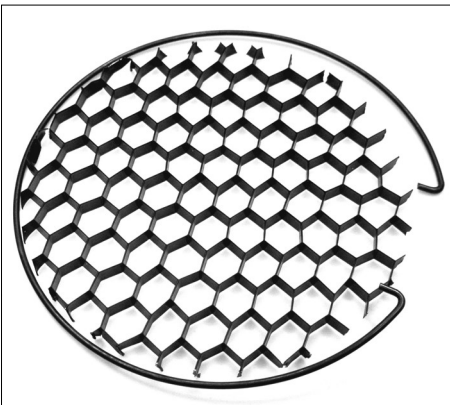

Description:

Honeycomb Filters are used to provide a more acute cut-off angle for reducing glare from spotlights. The honeycomb aperture reduces the visibility of the luminaire aperture for observers, and can be particularly useful when an arrangement requires luminaires to be aimed close to the line of site of users. The filter also has the effect of slightly tightening and sharpening the beam by cutting off distribution in the wider angles.

Honeycombs are available to suit all four OptaTube sizes — OptaTubes 60, 80, 110, and 130.

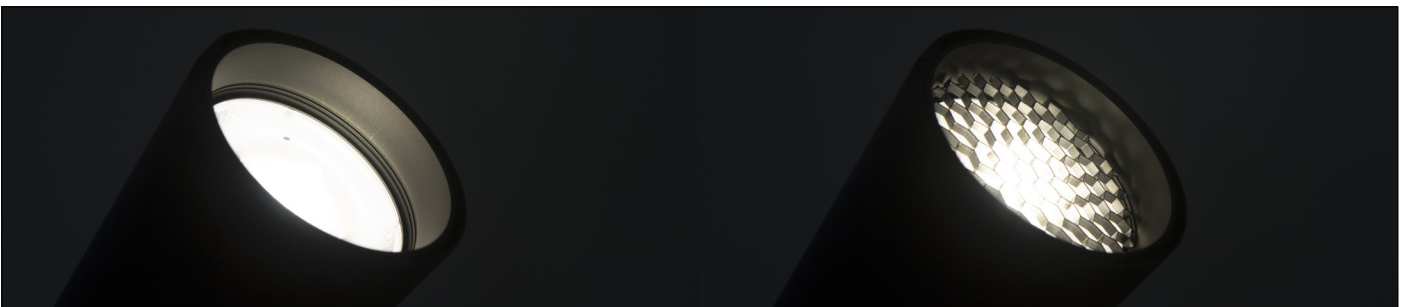

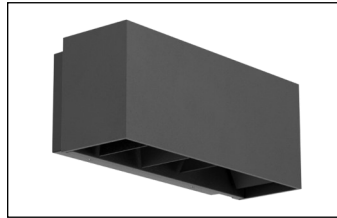
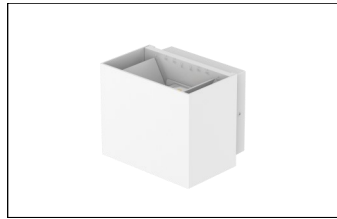
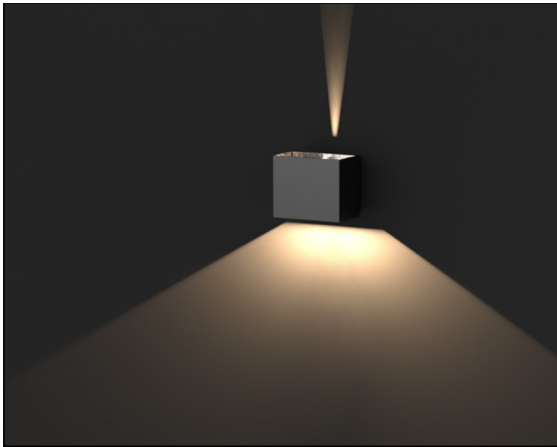

Description:

Few forms could offer more simplicity than the cube, and the OptaCube luminaire combines that classic appearance with highly customisable lighting effects. Adjustable reflector plates in both the up and down directions mean that distributions from a narrow 15° right through to a wide 120° can be configured (and re-configured whenever desired). Robust aluminium construction and an IP65 rating mean that OptaCube can be deployed in a wide range of applications.

Mounting:

Wall-mount, interior or exterior environments.

Key Applications:

Commercial, retail, public and residential building façades, Foyers, Entrances etc.

GENERAL SPECIFICATIONS:

Electrical Supply	220-240 V AC / 50-60 Hz
Driver Specifications	> 0.9 PF (>0.95 typ.), constant-current, integrated
Dimming Options	Non-dim
Colour Specifications	3000K, 4000K / R _a > 80
Operating Temperatures	- 20 to 45 deg. C
Construction	Cast and extruded aluminium body, PC optical cover
Colour Options	Black, White

STANDARD MODELS

Type	Size (mm)	Mass (kg)	Optic	Power	Flux*	Lumen Maintenance**
OptaCube 120	120 x 100 x 97	0.6	Adjustable (15° ~ 120°)	10 W	970 lm	L90 @ 18,000 hrs (B10) L80 @ 37,000 hrs (B10)
OptaCube 240	242 x 100 x 98	1.1	Adjustable (15° ~ 120°)	18 W	1,270 lm	L90 @ 24,000 hrs (B10) L80 @ 49,000 hrs (B10)

Notes:

* Flux values relate to CRI>80, 4000K versions.

** Lumen maintenance per TM-21 at t_a 25° C (9,000 hrs LM-80 data; predictions beyond 54,000 hrs are outside of TM-21 reporting guidelines and indicative only).

POLAR DIAGRAM

OptaCube 120 (Widest settings)

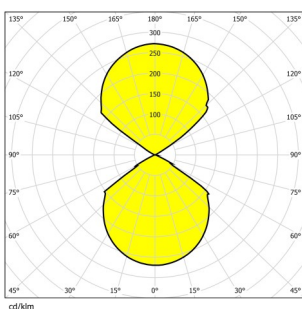

DIMENSIONS

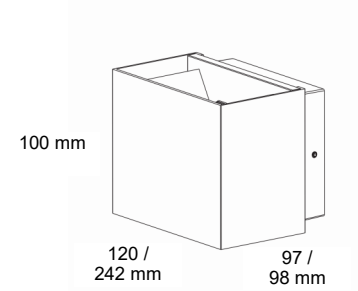



Description:

The OptaVert re-thinks how lighting can be used for multiple purposes — providing targeted task lighting as well as a creating prominent point of visual attraction. The semi-transparent vertical panel emits diffuse light to the sides, and — with graphics applied to it — could create a high-impact sign, even when switched off. Direct task lighting is channelled through either low-glare cellular reflector optics or a smooth opal diffuser.

Mounting:

Suspended; individual or two linked luminaires.

Key Applications:

Meeting rooms, Receptions, Foyers, Hospitality, Check-in and Check-out counters, Retail etc.

GENERAL SPECIFICATIONS:

Electrical Supply	200-240 V AC / 50-60 Hz
Driver Specifications	> 0.9 PF (>0.95 typ.), THD<15%
Dimming Options	Non-dim, DALI, CASAMBI
Colour Specifications	4000K (3000K, 5000K opt.) / R _a > 80 / 3 SDCM
Operating Temperatures	- 20 to 45 deg. C
Construction	Extruded alum. frame, PMMA vert. diffuser, PC direct optics
Colour Options	Silver

STANDARD MODELS

Type	Size (mm)	Mass (kg)	Optic	Power	Flux*	Lumen Maintenance**
OptaVert	1141 x 190 x 33	2.8	Low-glare reflector	50 W	6,000 lm	L90 @ 50,000 hrs (B10)
OptaVert	1200 x 140 x 40	3.0	Opal diffuser	50 W	5,700 lm	L90 @ 50,000 hrs (B10)

Notes:

* Flux values relate to CRI>80, 4000K versions.

** Lumen maintenance per TM-21 at t_a 25° C (9,000 hrs LM-80 data; predictions beyond 54,000 hrs are outside of TM-21 reporting guidelines and indicative only).

POLAR DIAGRAM

OptaVert Low-glare, 50 W

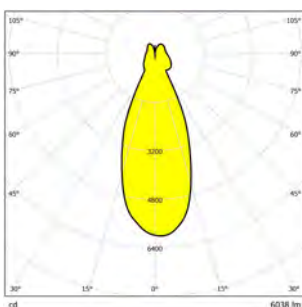

DIMENSIONS

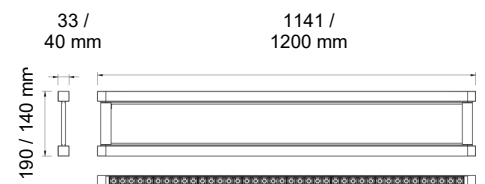

GLOSSARY



Ingress protection - expressed by an 'IP##' rating, where the first digit (from 1 to 6) indicates increasing protection against the ingress of solids/bodies and the second digit (from 1 to 8) indicates increasing protection against the ingress of moisture/water. Simple 'enclosed' (i.e. IP20-rated) luminaires are typically adequate for most commercial interior environments, although dust-proof (i.e. IP5X) luminaires typically require less frequent cleaning. Luminaires being used in damp locations (i.e. bathrooms, showers) normally require IP44 ratings or greater, while luminaires in exterior environments normally require IP54 ratings if installed in sheltered locations or IP65 or greater if installed in exposed locations.



Warranty policy - Ecopoint sells most of its products subject to a product warranty. The warranty provided to the customer is covered by the specific Terms & Conditions of Sale. You can download the full warrantee here: <https://ecopoint.co.nz/assets/Documents/Standard-Terms-and-Conditions-V3.3-2018.pdf>



Dimming - refers in general to the capability of adjusting a luminaire's flux across a range from full power down to a specified minimum (often 10%, but sometimes lower). Dimming can be controlled in a number of ways, but the typical methods used in commercial lighting are DALI (a digital communication protocol), 1-10V (uses a low-voltage analogue signal) or phase/mains dimming (regulates the supply voltage to the luminaire).

Flicker - in LED lighting flicker occurs as a result of modulating the current to electric light sources. Even though the human visual threshold is about 50Hz, if a light source is flickering faster than 50 times per second, this sub-stroptic flicker can still have a negative impact on health, wellness, and productivity.

Flicker;



- Can induce seizures in people with photosensitive epilepsy.
- Can contribute to headaches, eye strain, and fatigue impacting on productivity.
- Is a visual trigger that studies show can account for 38% of reported migraines.
- Can negatively impact individuals with autism due to their visual hypersensitivity, with lighting triggers heightening symptoms
- Can cause stroboscopic effect, which can pose hazards when using fast-moving machinery.
- Can render barcode scanners ineffective, as scanners won't function under flickering lights, creating issues for retailers.



Colour tolerance - expressed by MacAdam Ellipses or Standard Deviation of Colour Matching (SDCM); describes the differences in light colour from one LED to another (or one luminaire to another). When LED chips are manufactured, tolerances occur which can result, among other things, in differences in light colour. LEDs are therefore tested after they are manufactured and sorted into tolerance classes. If the colour (chromaticity) coordinates of a set of LEDs all fall within 1 SDCM (or a "1-step MacAdam ellipse"), most people would fail to see any difference in colour. If the colour variation is such that the variation in chromaticity extends to a zone that is twice as big (2 SDCM or a 2-step MacAdam ellipse), you will start to see some colour difference. It is typically accepted that a colour tolerance of 4 SDCM or less for commercial lighting will result in minimal noticeable variations for a casual observer.



Glare - the presence of bright light (in high contrast to its surrounds) which can either cause discomfort or simply impair vision. In a lighting context, glare is quantified by the **Unified Glare Rating (UGR)** which is a dimensionless scale with a lower figure indicating less glare. Ratings typically fall within the range of 13 (just perceivable) through to 28 (uncomfortable for extended periods). Office lighting standards typically require a UGR value of 19 or less.

Notes

Notes



Ecopoint New Zealand

Wellington (Head Office)

2 Jarden Mile, Ngauranga

+64 4 499 3636

info@ecopoint.co.nz

Auckland

Unit C / 1 Tony Street, Henderson

0800 695 949

info@ecopoint.co.nz

Christchurch

17 Wyber Place, Kaiapoi

0800 695 949

info@ecopoint.co.nz